



## License Plate / Turn Signal Relocation Kit - Model STBMS-02

### Application

Harley Davidson **2013 and later Dyna Street Bob** Rev 2/9/2017

Before you begin, read and understand these instructions and check to be sure all parts are accounted for.

<u>Qty.</u>	<u>Part Description</u>
1	Mounting Bracket
1	Lighted License Plate Frame
4	5/16 Button Head Bolts with Flat Washers and Nylon Lock Nuts
2	5/16 Hex Head Bolts with Flat and Lock Washers
4	Black Screws with Nylon Lock Nuts
2	Electrical Connectors
2	Tear Drop Fillers
	<b><u>Required Additional Parts</u></b>
2	Wing Standoffs (Optional parts purchased with this kit)
	<b><u>or</u></b>
1	Harley Davidson wing standoff purchased from dealer (Chrome=PN 69438-06, Black=PN 69933-08)
	<b><u>One of the options is required for installation</u></b>

### Installation Instructions

**Note:** A licensed Harley Davidson technician should be consulted before beginning installation of the STBMS-02 Kit. The following instructions are intended to provide general instructions for the installation of the relocation kit.

1. Place the motorcycle on a safe and secure motorcycle jack. Unbolt the lower rear shock bolts and lower the tire to access the turn signals, wires and license plate light wire (See fig.1). Lowering the tire will make installation of the kit possible.
2. Remove the seat to access the turn signal and license plate light plugs (See fig. 2). The electrical plugs can be removed and reinstalled after installation of the Mounting Bracket to avoid cutting the turn signal wires. The wires must be reinstalled in the plug exactly as removed. The license plate light wires will need to be cut to connect to the lighted license plate frame wires.
3. Remove the rear turn signals and license plate frame from the motorcycle (See fig.3). The Directional Standoffs will be replaced by the new Directional Standoffs (if ordered) or the Harley Davidson Directional Standoff (purchased separately from your local Harley Davidson dealer) when the turn signals are reinstalled.
4. Install the license plate and lighted frame onto the Mounting Bracket using the supplied screws with nylon lock nuts. (Note: a small notch at the top center of the license plate may be required to allow for lighted license plate frame wires)
5. Attach the lighted license plate frame wires to the license plate light wires from the motorcycle using the supplied connectors.
6. Install the Mounting Bracket onto the motorcycle using the 5/16 button head bolts, 5/16 Flat washers, 5/16 nylok nuts and the tear drop filler. The Mounting Bracket will mount between the rear fender mounting bracket and the fender. The rear hole of the Mounting Bracket will slip over the boss in the rear fender mounting bracket. The tear drop filler and 5/16 button head bolts will mount into the rear turn signal recess and bolt to the Mounting Bracket with the 5/16 nylok nuts and 5/16 flat washers.
7. Install the rear turn signals onto the Mounting Plate using the 5/16 hex head bolts with flat and lock washers. Reinstall the wires through the fender to a point under the seat. Install the lighted license plate frame wires to the existing license plate light wires to a secure point. Reinstall the electrical plugs and reconnect to the bike. Route all electrical wires to assure clearance from tire.
8. Reinstall the rear shocks and seat. Verify interior clearance from tire to bolts.

### Notice to Consumer

Neither the manufacturer, nor the distributor or the retailer of the Mounting System makes any express warranties of any kind with respect to the Mounting System. Any implied warranty does not cover defects caused by modification or alterations of the Mounting System or caused by physical abuse to or misuse of the Mounting System or its use and/or operation in a manner contrary to the accompanying instructions. Failure to install and/or use the Mounting System in the manner described by the accompanying instructions shall render all warranties, expressed and/or implied, void and release the manufacturer, distributor and retailer from any and all liability arising from the use of the Mounting System,.

**For product support, damaged or missing parts, please contact Great Bike Gear, Inc. at 866-521-3024  
Do not return product without prior authorization.**

**SEE REVERSE SIDE FOR ILLUSTRATIONS**



Motorcycle on Jack with Shocks Disconnected



Access to wire connections



Rear Fender Mounting Bracket



Mounting Bracket Installed



Turn Signals Installed



Installation Complete

### Turn Signal Connector Removal

1. After removal of the tail light lens, disconnect the turn signal connector from the electrical terminal by depressing the Release button. (1)
2. Open the Secondary lock. (3) Note the wire color locations for correct reconnection.
3. Using a Pin or small screw driver (6) release the Tang (4) from the Socket terminal (5) while gently pulling the wire from the connector.
4. Reverse the procedure for reconnection.

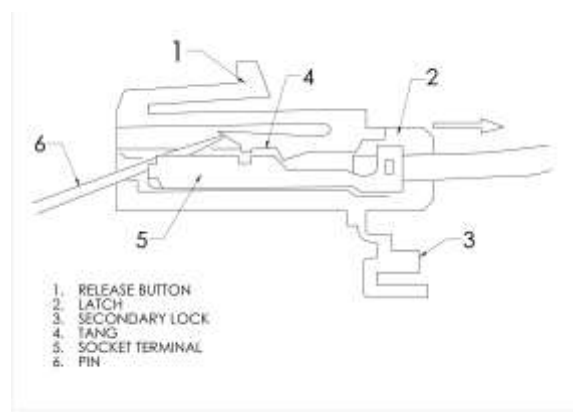

SEE REVERSE SIDE FOR ILLUSTRATIONS